



Version 2.7

**Traffic Generator for IP Networks (IPv4 & IPv6)
FTTx, LAN, MAN, WAN, WLAN, WWAN, Mobile, Satellite,
PLC, etc.**

Product Overview

The **LanTraffic V2** software generates traffic for IP networks by using the following protocols: TCP (Transmission Control Protocol), UDP (User Datagram Protocol), ICMP (Internet Control Message Protocol) or SCTP (note i) (Stream Control Transmission Protocol – for 32-bit OS only).

The add-on software called **Automation Tool for LanTraffic V2** allows automating operations with **LanTraffic V2**. For instance, you can run test campaigns automatically.

Various testing configurations can be implemented using more than two PCs. **LanTraffic V2** creates TCP or UDP connections between PCs through the IP network. **LanTraffic V2** creates also SCTP (note i) and ICMP connections.

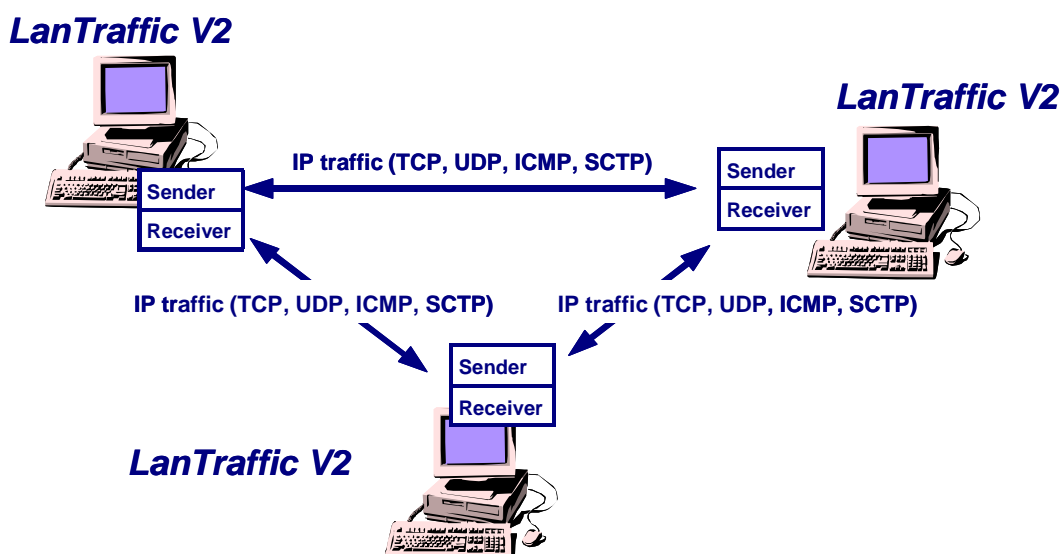

Product Requirements

- Pentium PC running Windows XP, Server 2003, Vista, Seven or Server 2008 - with at least 128 MB Ram.
- 15 MB free hard disk space.
- Acrobat Reader is needed to display the help.
- 1024 x 768 display and DPI setting = Normal size (96 DPI).
- One Network Interface Card (LAN, WLAN, etc.)



Note: Windows XP or later is required to use IPv6.

Products features

The **LanTraffic V2** testing tool is made of a **Sender** part and a **Receiver** part.

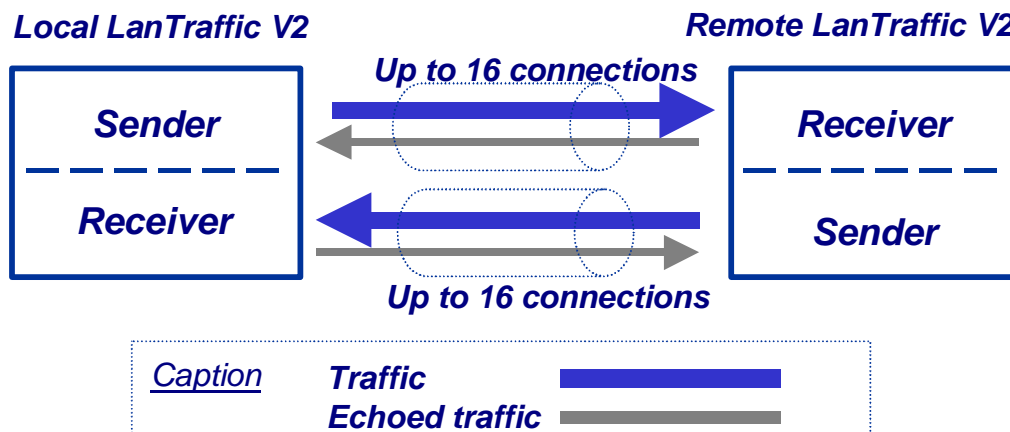

- The **Sender** generates up to 16 simultaneous UDP (Unicast, Multicast or Broadcast) and/or TCP connections and/or SCTP ^(note i) connections and/or ICMP connections. The connections can be established in two different testing modes:

Unitary Mode: you can select the traffic generator data source and configure packets size and inter packet delay for each connection. With the ICMP protocol you can:

- ⇒ ICMP Echo request packet number and content: packet generator (fixed, randomized, alternated and increasing / decreasing).
- ⇒ ICMP Echo Request data size: fixed, randomized, alternated and increasing / decreasing.
- ⇒ ICMP Echo Reply receiving timeout: fixed, randomized, alternated, increasing / decreasing or use of a mathematical law.

LanTraffic V2 offers three different data sources:

- Automatic data generator by using mathematical laws,
- Packets generator: many parameters can be defined (number of packets to send, inter packet delay, packet contents, ...)
- File: selection of a file to send.

⇒ **Automatic Mode:** select one mathematical law for connections generating (up to 16 connections) and starting time, and then select a second mathematical law for data volume to be sent. This mode is available with UDP and TCP only. With this mode, SCTP ^(note i) and ICMP connections can not be started.

⇒ **Statistics:** for each connection the following statistics parameters are displayed by the **Sender** and can be saved in a file:

- Sent throughput⁽²⁾
- Received throughput^{(1) (2)}
- Sent packet throughput⁽²⁾
- Received packet throughput^{(1) (2)}
- Sent data volume⁽²⁾
- Received data volume (volume of data sent by the remote)^{(1) (2)}
- Sent packets
- Received packets (packets sent by the remote)⁽¹⁾
- Data volume to send⁽²⁾
- Remaining volume (of data to send)⁽²⁾
- Sequence numbering errors⁽¹⁾
- RTT Mean (Round Trip Time)⁽¹⁾
- Jitter^{(1) (2)}

⁽¹⁾ These statistics are not available with SCTP ^(note i) protocol.

⁽²⁾ These statistics are not available with ICMP protocol.

- The **Receiver** receives traffic (up to 16 simultaneous connections) and operates five different working modes: Absorber, Absorber File, Generator, Echoer and Echoer File. With SCTP ^(note i) protocol, only the Absorber and Absorber File working modes are available. SCTP ^(note i) can not be used on both Sender and Receiver parts at the same time.
- Each Receiver connection can be set up according to one of the following five modes:

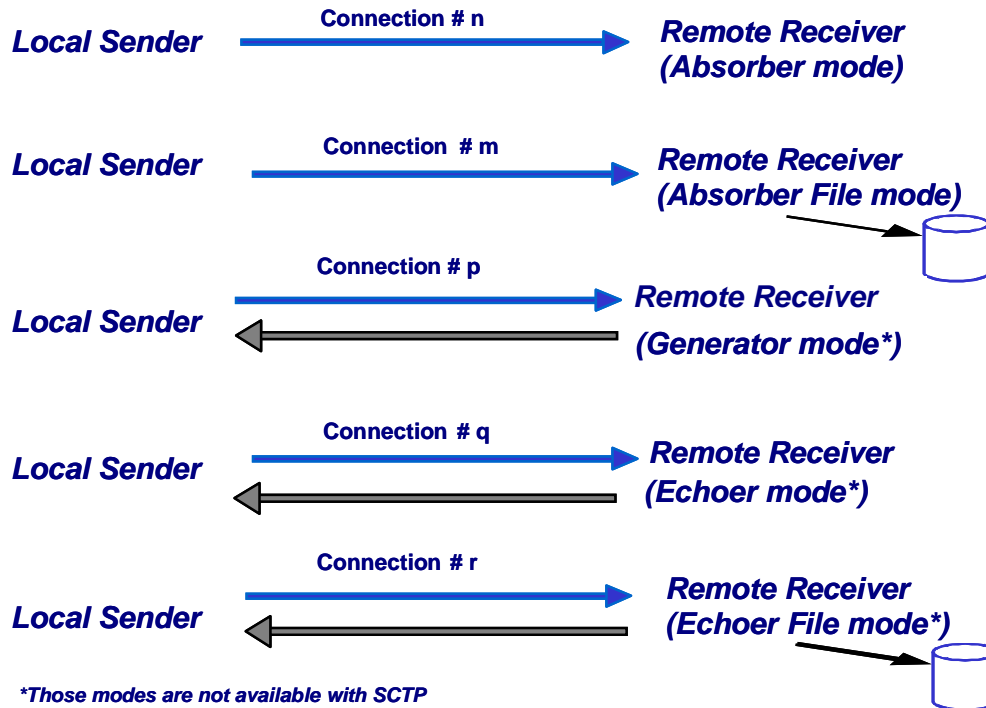

Note: We consider that the local machine is used for sending traffic and the remote one is used for receiving traffic.

- ⇒ **Statistics:** for each connection the following statistics parameters are displayed by the **Receiver** part and can be saved in a file:
- Sent throughput⁽¹⁾
 - Received throughput
 - Sent packet throughput⁽¹⁾
 - Received packet throughput
 - Sent data volume⁽¹⁾
 - Received data volume (volume of data sent by the remote)
 - Sent packets⁽¹⁾
 - Received packets (packets sent by the remote)
 - Data volume to send⁽¹⁾
 - Remaining volume (of data to send) ⁽¹⁾
 - Sequence numbering errors
 - Data not echoed⁽¹⁾
 - Jitter

⁽¹⁾ These statistics are not available with SCTP ^(note i) protocol.

::: Unicast, Multicast and Broadcast feature

LanTraffic V2 is able to generate and receive Unicast, Multicast (IPv4 and IPv6). and Broadcast (only with IPv4) IP traffic. The multicast and the broadcast features are available with the UDP protocol only.

::: IP version selection

LanTraffic V2 supports IPv6 for Windows XP and later versions (i.e. Server 2003, Vista, Seven, etc.).

***LanTraffic V2** supports the IPv6 numerical address format (128 bits long) as well as canonical addresses. The IPv6 multicast is available with **LanTraffic V2** in accordance to RFC 2373 where a multicast IPv6 address starts with FF.*

With IPv6 the maximum size of the TCP packet is **1440** bytes whereas it is **1460** bytes with IPv4.

::: Interface selection

The interface selection of a LAN card (NIC), a virtual NIC such as an IP tunneling protocol or a remote access is useful to control the data traffic hardware route.

LanTraffic V2 is able to generate and receive Unicast, Multicast and Broadcast IP traffic on a selected interface, giving the user a deeper control where data are exchanged and makes multiple routes definition easier. The interface selection is not available with SCTP ^(note i).

::: Statistics values

Statistics values presented by **LanTraffic V2** are calculated at the Application level. They don't include the protocol header, the IP header nor data link header and/or trailer.

The Automation Tool for LanTraffic V2

The add-on software **Automation Tool for LanTraffic V2** allows you to edit scenarios, carry out scenarios, set the **LanTraffic V2** parameters and pilot **LanTraffic V2** automatically on the same PC.

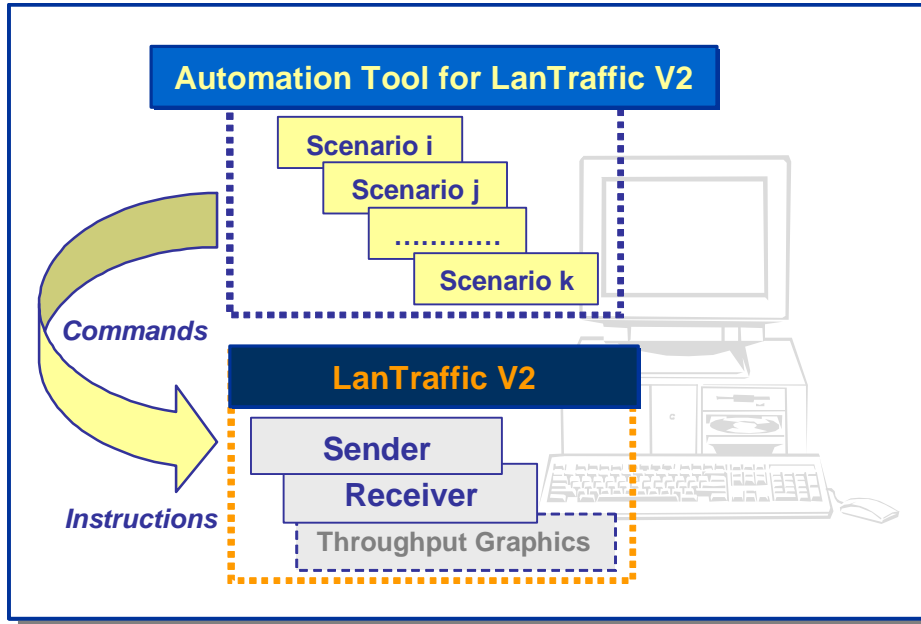

A scenario is a succession of **commands** and **instructions**.

A **command** is used to set parameters and/or activate a function of **LanTraffic V2**.

For example the *Set and Start connection(s)* command helps to set parameters for IP connections and to start the traffic on these connections. With such command you specify the IP address, port number, protocol, packet size, inter packet delay, duration, etc. and you start the traffic generation for these connections.

An **instruction** is used by the Automation Tool to create an internal process. For example, the *Wait Date/Time* instruction suspends the scenario execution up to the specified date and time before to continue.

By using the **Automation Tool for LanTraffic V2** you can:

- Set automatically the parameters of the **LanTraffic V2** software,
- Start and stop IP connections based on timers,
- Execute the scheduled operations in accordance with your own timing,
- Make repetitive tests operations automatically,
- Simplify the tests reproduction,
- And more...

Customer references

Present on the market since 1997, **LanTraffic V2** is used in more than 40 countries.

See some worldwide references of satisfied customers:

ABN Amro, Alcatel, Aramco, Ascom, Avaya, Bloomberg, Cisco, Easynet, EDS, Ericsson, Equant, France Telecom, Intracom, Iwatsu, Kingston, Lucent, Motorola, Mutsumi, Netscout, Nokia, Nortel Networks, Novartis, NTT, Philips, Pinnacle, Qantas, QBE, Schlumberger, Siemens, Telefonica de Espana, Telefonica del Sur, Thales, Tiscali, Tropos Networks, Unisys, UnumProvident, US Army, USDoJ, US Navy, Vipersat, etc. as well as many universities and telecom institutes.

Conditions of use

LanTraffic V2 is licensed on a per workstation basis. You will need to purchase a separate license for each machine that you install it on.

Each licensed copy of the software installed on a workstation has a unique Site Code that requires the corresponding unique Site Key to be entered before being operational.

Delivery

Includes CD with documentation, printed installation guide, technical support and software maintenance (including major and minor software upgrades) for a period of twelve months from the date of purchase.

To download an evaluation of **LanTraffic V2**, please visit us at:
<http://www.zti-telecom.com/pages/main-ip.htm>

ⁱ SCTP is only available with Windows 32-bit OS. It may require additional configuration e.g. Windows firewall and Administrator rights depending on the target OS.