



Version 4.7

Impairment Emulator Software for IP Networks (IPv4 & IPv6)

The screenshot displays the NetDisturb Client software interface, titled "Impairment Tool for IP Networks - TCP Aggregate.WSX". The interface is divided into several sections:

- Flows to impair using filters:** A list of 16 TCP flows (e.g., TCP port 2009, 2010, etc.) with "View" and "Stop" buttons.
- Flow #01 Configuration:** Detailed settings for "Flow #01: TCP port 2009". It includes:
 - Loss & Duplication:** "Percentage of Loss" dropdown, "Router Simulation with Delay" dropdown, and "Loss: Percentage" input.
 - Delay & Jitter Law:** "Router Simulation & Constant Delay" dropdown, "Router Simulation & Constant Delay" input, and "Delay" button.
 - Content Impairment:** "Percentage" dropdown and "Percentage" input.
 - Application Rules:** "Waiting for trigger" dropdown, "Impairments on A to B" dropdown, "Lost/Dupl. Pkts" (0), "Delayed Pkts" (0), and "Modified Pkts" (0).
 - Statistics:** "Incoming on A" (Packets: 0, Pkts/s: 0, Throughput: 0.00 bits) and "Outgoing on B" (Packets: 0, Pkts/s: 0, Throughput: 0.00 bits).
- Impairments to apply on packets going from B to A:** Similar configuration section for the reverse direction.
- Interfaces-Statistics:** A table showing statistics for "A Interface" and "B Interface".
- Aggregates Panel:** A list of 16 aggregate flows with color-coded indicators.
- Help:** A section explaining the aggregate flow concept.

	Throughput	Reception	Received Pkts	Filtered Pkts	Sent Pkts	Throughput	Transmission
From A to B	0.00 bits	0 p/s	0 p	0 p	0 p	0.00 bits	0 p/s
From B to A	0.00 bits	0 p/s	0 p	0 p	0 p	0.00 bits	0 p/s

Performance Characteristics on Gigabit networks

Abstract

To measure the performance of impairment emulation software one needs to consider multiple aspects. Performance is mainly linked to:

- A- Physical throughput
- B- Number of packets sent per second

These metrics determine the capability of the impairment emulator not to introduce unhandled impairments, other than the user-defined impairments, due to software limitations. This document summarizes results achieved with **NetDisturb V4.7** for a Gigabit Ethernet configuration with copper interface. Tests were conducted at the ZTI Test Lab.

1 Introduction

This document provides an overview of performance that can be expected from **NetDisturb** with the same configuration as tested in our lab. Users may get better performance than the one presented in this document with a more powerful PC, with other Ethernet architectures or NICs.

For these tests, a Server PC has been used. A Gigabit network needs fast PCs to make tests. The PCs selected guarantees efficient CPU, memory and disk subsystem architecture with Windows XP Pro with Service Pack 2.

LanTraffic V2 version 2.6.4 is used to generate IP flows. This choice is based on the simplicity of this software to create a strong flow even from desktop computers. **LanTraffic V2** is running under Windows Vista to get the highest performances on the gigabit network.

NetDisturb version 4.7.0 is used for all tests. Both **NetDisturb** Editions have been used with the same context file. No other software other than **NetDisturb** has been activated to avoid decreasing the CPU availability. Note that antivirus software and/or Windows Firewall should be switched off in order to obtain the best performance.

This document is organized as follows:

- **Throughput Measurements Results**

This section shows the results obtained in our labs.

- **Description of the two tests benches**

This section describes the architecture of the two tests benches used and the parameters used.

- **Appendix**

This section provides additional information regarding hardware configurations.

2 Throughput Measurements Results

More details about the configurations used can be found in § 3 Description of the two tests benches.

2.1 Throughput Measurements

The table 1 and the table 2 show the maximum throughput that **NetDisturb** can handle. These results were obtained with the configuration 1 (refer § 3.1 Configuration 1: Throughput Performance Measurements)

Number of IP flows activated	Incoming and Outgoing Throughput*
0 (Other Flows activated)	980 Mb/s
1	980 Mb/s
16	975 Mb/s

Table 1 - Gigabit measurements with TCP packets

Number of IP flows activated	Incoming and Outgoing Throughput*
0 (Other Flows activated)	970 Mb/s
1	970 Mb/s
16	970 Mb/s

Table 2 - Gigabit measurements with UDP packets

* Throughput data is based on the MAC level data, i.e. it's the Ethernet throughput.

2.2 Packets Throughput Measurements

The tables 3 to 6 show the maximum number of packets per second that **NetDisturb** can handle. These results were obtained with the configuration 1 (refer § 3.2 Configuration 2: Packets Throughput Performance Measurements)

Number of IP flows activated	Incoming and Outgoing Throughput
0 (Other Flows activated)	202 000 packets/s
1	192 000 packets/s
16	149 000 packets/s

Table 3 - Gigabit measurements with UDP packets (Ethernet Frame size: 64 bytes)

Number of IP flows activated	Incoming and Outgoing Throughput
0 (Other Flows activated)	176 000 packets/s
1	169 000 packets/s
16	135 000 packets/s

Table 5 - Gigabit measurements with UDP packets (Ethernet Frame size: 546 bytes)

Number of IP flows activated	Incoming and Outgoing Throughput
0 (Other Flows activated)	193 000 packets/s
1	187 000 packets/s
16	151 000 packets/s

Table 4 - Gigabit measurements with UDP packets (Ethernet Frame size: 206 bytes)

Number of IP flows activated	Incoming and Outgoing Throughput
0 (Other Flows activated)	80 500 packets/s
1	80 500 packets/s
16	80 500 packets/s

Table 6 - Gigabit measurements with UDP packets (Ethernet Frame size: 1518 bytes)

CPU and bus type are critical elements

The number of CPUs and the hyper threading systems help to handle interruptions generated by packets exchanges. Capacity to handle interruptions limits the number of packets that can be exchanged. During those tests the CPU usage was around 40%.

Hardware component quality is crucial to obtain the best performance

During tests up to 210 000 packets/s have been generated but only around 190 000 packets/s were received by **NetDisturb**. This might be due to limitations of the network adapter. Best performance can be expected with more efficient NICs.

3 Description of the two tests benches

3.1 Configuration 1: Throughput Performance Measurements

PC1 sends data to PC2 and PC3. **NetDisturb** is installed on PC4. All PCs are linked to the DLink Gigabit Switch using category 6 draft 10 cables. A Category 6 draft 10 cross cable is used to link PC1 and PC4.

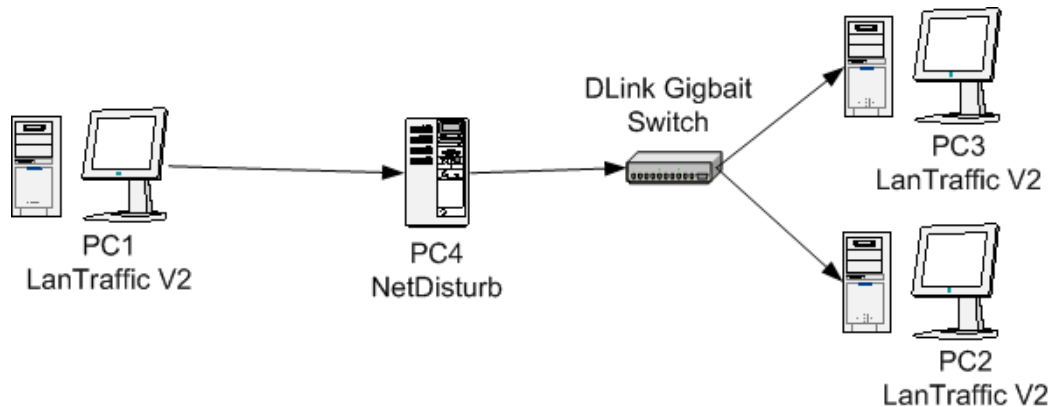

LanTraffic V2 Unitary Testing Mode is selected and the default values (menu File/new) are kept except for these particular values listed hereafter:

	TCP Data Size	UDP Data Size
IPv4	1460 bytes*	1472 bytes*

*This is the maximum data size required to prevent IP fragmentation that could decrease performance.

3.2 Configuration 2: Packets Throughput Performance Measurements

PC1, PC2 and PC3 send data to PC5. **NetDisturb** is installed on PC4. All PCs are linked to the DLink Gigabit Switch using category 6 draft 10 cables. A Category 6 draft 10 cross cable is used to link PC4 and PC5.

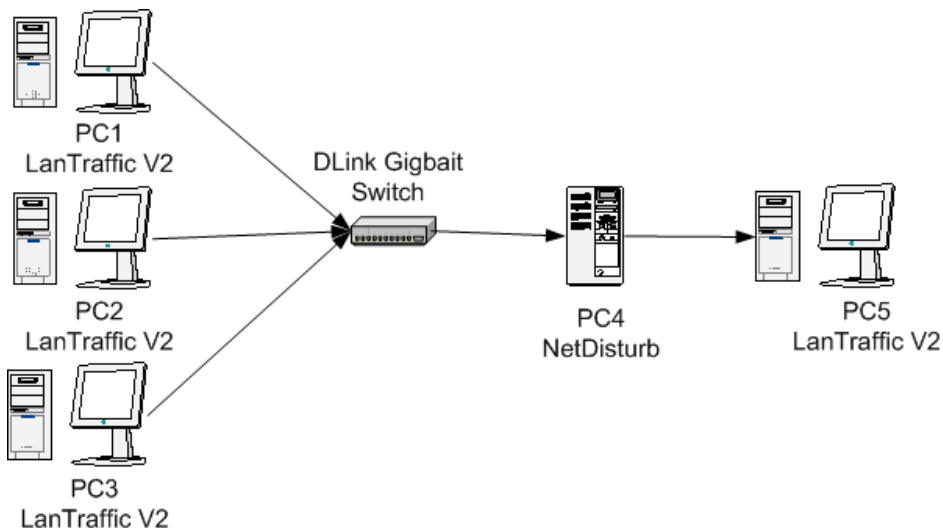

LanTraffic V2 Unitary Testing Mode is selected and the default values (menu File/new) are kept except for these particular values listed hereafter. Different UDP data sizes are used to realize these tests.

UDP Data Size	1 byte	160 bytes	500 bytes	1472 bytes*
---------------	--------	-----------	-----------	-------------

*This is the maximum data size required to prevent IP fragmentation that could decrease performance.

4 Appendix

PC1

- Manufacturer: DELL OptiPlex GX745
- Operating System: Windows Vista, Service Pack 1
- CPU: Intel Dual Core 2 E6600 2.4 Ghz
- RAM: 1 GB
- NIC: Broadcom NetXtreme Gigabit Ethernet PCI Express Adapter (ASIC Version: BCM 5751 C1)

PC2

- Manufacturer: DELL OptiPlex GX280
- Operating System: Windows Vista, Service Pack 1
- CPU: Intel Pentium 4 - x86 family 15 Model 4 Stepping 1 GenuineIntel~3 Ghz
with Hyper threading activated
- RAM: 1 GB
- NIC: Broadcom NetXtreme Gigabit Ethernet PCI Express Adapter (ASIC Version: BCM 5751 C1)

PC3

- Manufacturer: DELL OptiPlex GX280
- Operating System: Windows Vista, Service Pack 1
- CPU: Intel Pentium 4 - x86 family 15 Model 4 Stepping 1 GenuineIntel~3 Ghz
with Hyper threading activated
- RAM: 1 GB
- NIC: Broadcom NetXtreme Gigabit Ethernet PCI Express Adapter (ASIC Version: BCM 5751 C1)

PC4

- Manufacturer: DELL Power Edged 1900
- Operating System: Windows XP Professional Version 2002, Service Pack 2
- CPU: 2 Intel Xeon Dual Core 5140
- RAM: 1 GB (667 Mhz)
- NICs: 2 Intel Pro/1000 PT Server Adapter (PCI Express)

PC5

- Manufacturer: DELL Power Edged 1750
- Operating System: Windows XP Professional Version 2002, Service Pack 2
- CPU: 2 Intel Xeon Dual Core 5140
- RAM: 1 GB (667 Mhz)
- NIC: Broadcom NetXtree 57xx Gigabit Adapter (Embedded)

DLink Gigabit switch DGS 1004T

- Ethernet/Fast Ethernet/Gigabit Ethernet auto-sense
- Full duplex 10/100/1000 capabilities
- 4 ports 10/100/1000 Mbps