



GPS Hardmount Antenna

5V, 28dB, TNC Connector



Revision 3

ZTI / 1 boulevard d'Armor / BP 20254 / 22302 Lannion Cedex / France

Contact Email: sales@tele-line.com.hk / www.tele-line.com.hk

*The specifications in this document are subject to change without Notice.
ZTI is not responsible for the operation or failure of operation of GPS satellites or the availability of GPS satellite signals.*

Key Features

- Waterproof (submersible to 1 meter) and environmentally sealed
- Proven extra rugged, reliable
- Available in 'TNC' connector
- Very good ground plate and easier mounting with TNC cable right angle
- Designed for vehicles
- RoHS-Compliant (Pb-free)



Presentation

Housed in a compact, low-profile package, the Hardmount Antenna is well-suited to mobile positioning applications. The Hardmount Antenna is a miniature patch antenna with a 25 dB preamplifier. The antenna is designed for installation on vehicles with a 0.75 inch mounting hole. The antenna comes complete with gasket and mounting nut. The antenna may be installed on flat surfaces up to 0.1 inch thick.

SUMMARY OF THE CHARACTERISTICS

SPECIFICATION	
Weight:	6.4 oz. (180g)
Dimensions:	2.48" dia. x 1.6" ht. (63mm dia. x 40.5 mm ht.)
Connector:	TNC
Mounting:	0.75 inch threaded mount
Operating Temp:	-40°C to + 85°C
Storage Temp:	-40°C to + 100°C
Prime Power:	4.75 ±0.5 V
Humidity:	20% to 95% R.H.
Waterproof:	Submersible to 1 meter
Frequency:	L1 (1575.42 MHz)
Power Consumption:	40mA max
Impedance:	50 OHMS
Polarization:	RHCP
VSWR:	2.0 max
Vibration:	10~200 Hz. Log. sweep 3
Axial Ratio:	90° : 3.0 dB min. 20° : 6.0 dB min
Gain:	28.0 dB
Noise:	2.0 dB max (+23°C) 2.5 dB max. (+80°C)

Mechanical

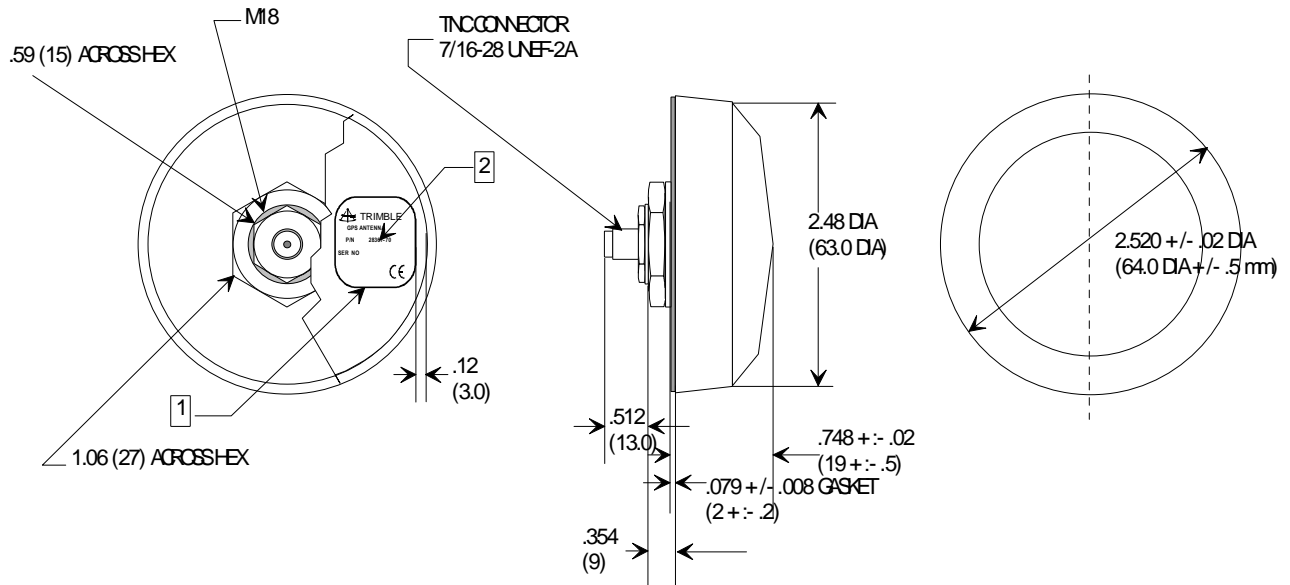

1.0 APPLICATION	THIS SPECIFICATION APPLY FOR THE ELECTRICAL AND MECHANICAL CONDITIONS OF GPS ANTENNA	
2.0 SYSTEM	THIS ANTENNA SYSTEM CONSISTS OF TWO FUNCTIONAL BLOCKS LISTED BELOW.	
2.1	RECEIVING ANTENNA	
2.2	LNA	
3.0 GENERAL		
3.1 ENVIRONMENTAL CONDITIONS		
3.1.1 OPERATING TEMPERATURE		-40°C TO +85°C
3.1.2 STORAGE TEMPERATURE		-40°C TO +100°C
3.1.3 RELATIVE HUMIDITY		20 % TO 95 %
3.2 ELECTRICAL SPECIFICATIONS		
3.2.1 INPUT VOLTAGE		4,75 V +/- 0,5 V
3.2.2 POWER CONSUMPTION		40 mA MAX
3.2.3 OUTPUT CONNECTOR		TNC
3.3 MECHANICAL SPECIFICATION		
3.3.1 MOUNTING		NUT MOUNT
3.3.2 WATERPROOF		IMMERSION TO 1 METER WATER FOR 24 HOURS
3.3.3 SHOCK		50G : VERTICAL AXES 30G : ALL AXES
3.3.4 VIBRATION		10~200 Hz. LOG.SWEEP 3.0G (SWEEP TIME/ 15 MIN), 3AXIS
3.3.5 CONFIGURE AND DIMENSION		SEE ATTACHED FIGURE
3.3.6 WEIGHT		180 g MAX

4.0	ANTENNA	
	4.1 FREQUENCY RANGE	1,575,42+/- 1.023 MHz
	4.2 GAIN	90° : 3.0dBi MIN 20° : -5.0dBi MIN (MOUNTED ON THE 65mm X65 mm SQUARE GROUND PLANE)
	4.3 POLARISATION	RHCP
	4.4 AXIAL RATIO	90° : 4.0dB MAX 10° : 6.0Dbn MAX (MOUNTED ON THE 65mm X65 mm SQUARE GROUND PLANE)
5.0	LNA	
	5.1 FREQUENCY RANGE	1,575,42 +/- 1.023MHz
	5.2 GAIN	27dB MIN
	5.3 NOISE FIGURE	1.8dB MAX (+25°C +/- 5°C) 2.3dB MAX (+80°C)
	5.1 OUT OF BAND RELECTION	
		$f_o=1,575,42$ MHz 7dB MIN
		$f_o\pm 20$ MHz 7dB MIN
		$f_o\pm 30$ MHz 12dB MIN
		$f_o\pm 50$ MHz 20dB MIN
		$f_o\pm 100$ MHz 30dB MIN
	5.1 OUTPUT IMPEDANCE	50Ω
	5.2 OUTPUT VSWR	2.0 MAX
6.0	TOTAL SPECICATIONS (THROUGH ANTENNA, LNA, CABLE AND CONNECTOR)	
	6.1 FREQUENCY RANGE	1,575,42 +/- 1.023MHz
	6.2 GAIN	28dBi MIN (-40°C ~+ 85°C)
	6.3 NOISE FIGURE	2.0DbMAX (+23°C) 2.5dB MAX (+80°C)
	6.1 OUTPUT IMPEDANCE	50Ω
	6.2 OUTPUT VSWR	2.0 MAX