



zClock

High Precision Clock



PRESENTATION

ZTI has designed a clock module with a very high degree of accuracy for use on PC parallel port (EPP mode).

The Real Time Clock (RTC) built into most machines is far from reliable and most RTCs drift considerably over time.

Based on a high stability and ultra stable OCXO (Oven-Controlled Crystal Oscillator) with a fast warm up, the zClock product offers a very precise clock (0,27 ppm) to PC applications in a small and compact packaging.

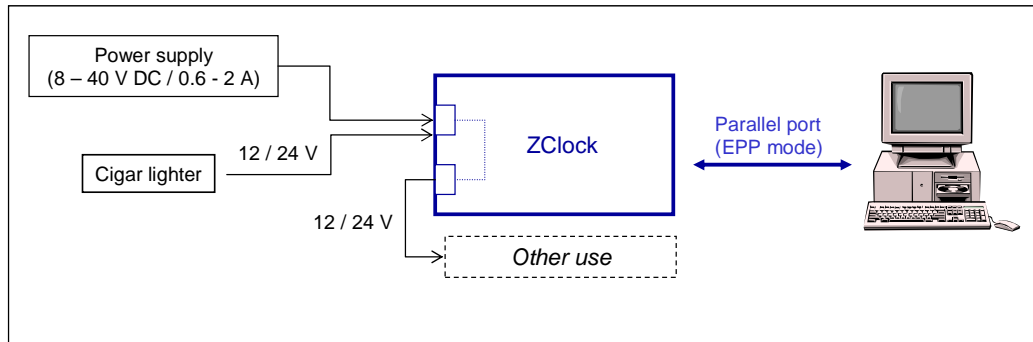

Note: the specifications in this document are subject to change without notice.

MAIN ADVANTAGES

- To offer to PC applications a very precise clock
- To be free from the problems of precision and drift of the PC clock
- Can be used with a desktop or laptop

How does it work?

Once zClock is powered on, the Red/Green bicolor led on the front face is red lighted (OCXO Warm Up is in progress < 5 mn). The bicolor led is green lighted as soon as zClock is operational (OCXO steady state).

The PC application can then use the zClock time reference via query / answer on the parallel port (Enhanced Parallel Port mode). An interrupt is generated on the parallel port from 200 microseconds up to 6,5535 seconds with a step of 100 microseconds.

Thus by using zClock, the application can rely on a precise clock with a drift lower than 1 millisecond for 1 hour on 1 year.

Example of use

ZTI has developed a software testing tool named 'IP Traffic—Test & Measure' to generate traffic and measure Quality of Service parameters over IP networks.

In order to have very accurate measurements (precision = 1 millisecond), a time device synchronized by GPS (to have an absolute time reference) and the zClock product are used.

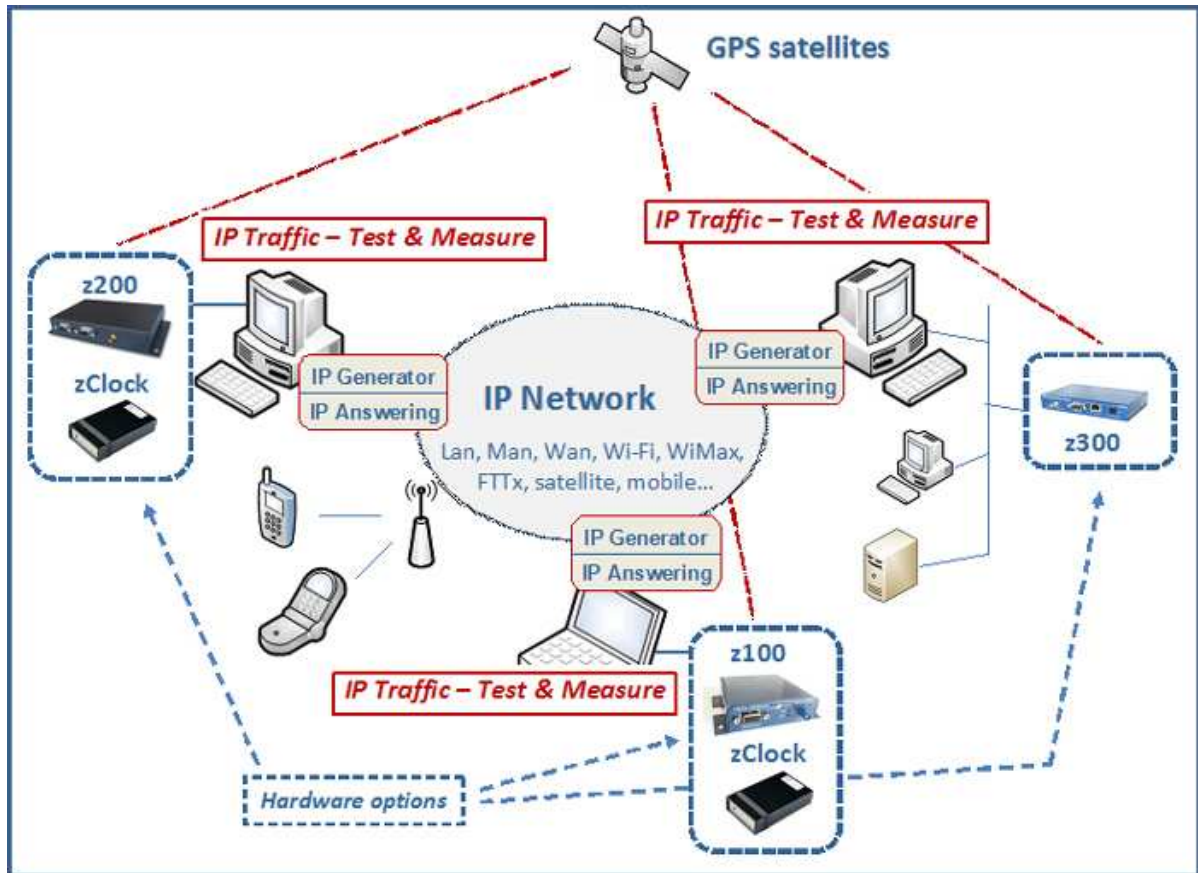

OCXO Specifications

<i>Frequency Stability</i>	OPERATING [0, +50] °C	< ± 5 × 10 ⁻⁸
<i>Medium and long term stability</i>	1 DAY	< ± 1 × 10 ⁻⁹
<i>(@ 25 °C after 30 days operation)</i>	1 MONTH	< ± 3 × 10 ⁻⁸
	1 YEAR	< ± 2 × 10 ⁻⁷
<i>Short Term Stability (Allan variance)</i>	1 s, 10 s	< ± 1 × 10 ⁻¹¹
<i>Warm Up Time @ 25°C</i>	± 1 × 10 ⁻⁸	< 5 minutes

Environment

<i>Temperature</i>	STORAGE	[-30, +70] °C
	OPERATING	[0, +50] °C
<i>Supply voltage</i>	8 - 40 V DC / 0.6 - 2 A	

Package

<i>Size</i>	157 x 94 x 36 mm
<i>Weight</i>	260 g

Consumption according to the entry voltage

Voltage (V)	8	10	12	15	20	25	30	35	40
Warm Up current (mA)	550	400	330	250	200	160	130	110	100
Steady state current (mA)	250	180	150	120	90	70	60	50	40

Interfaces

Front face:	1 Red / Green bicolor Led (Red / Green)
<i>Red</i>	Oscillator Warm Up (up to 5 minutes depending on the ambient temperature).
	In this state, zClock is not operational.
<i>Green</i>	zClock is operational.
Back face:	3 connectors
<i>Power input</i>	8 - 40 V DC / 0.6 - 2 A
<i>Power output</i>	8 - 40 V DC / 0 - 1.4 A (for other use)
<i>Parallel interface</i>	25 pts Sub-D (EPP mode only)



Conformance with standards and directives

zClock is in conformance with the following safety and electromagnetic compatibility Standards and Directives.

Safety

73/23 EEC, **Low Voltage Directive (Europe)**

IEC 60 950 (3rd edition, 1999) **(Worldwide)**

CB scheme, deviations for the following countries: Austria, Canada, Czechoslovakia, Denmark, Deutschland, Finland, France, Hungary, Norway, Poland, Russia, Singapore, Sweden, Switzerland, The Netherlands, United Kingdom, United States of America, South Africa.

Note: This list is not exhaustive. Others countries will be automatically added, as soon they will notify the 3rd edition of IEC 60 950 standard.

Electro-Magnetic Compatibility

89/336/ EEC Directive (Europe)

EN 50081-1 (1992)

EN 50082-1 (1997)

EN 61000-3-2 (1995) + A1 (1998) + A2 (1998) + A14 (2000)